

# WRAS certified MLCP Press Fitting

## Datasheet



# MLCP Press Fitting

## Features

Press-fittings have been designed to be used in conjunction with the Multilayer pipe as a press fit system with no requirement for hot works. This type of joint has become increasingly more popular due to its simple and quick installation, along with high working temperature and pressure capability.

The Press Jaw, specific for every diameter of fittings, compresses a stainless steel sleeve, which secures the pipe onto the core of the fitting. The hydraulic and mechanical sealing is guaranteed by the special profile of the fitting and the double O-ring. After pressing, the fitting produces a joint with maximum strength and durability.

## Construction Details

The stainless steel sleeve is connected onto the fitting by white plastic ring.

Each sleeve has the indication of the diameter .

The plastic ring has four important functions:

- ◆ it prevents di-electric contact between the layer of aluminium of the pipe and the brass body of the fitting, thus preventing the risk of possible corrosion
- ◆ it provides sight holes to ensure that the pipe has been fully inserted into the fitting
- ◆ it guides the correct positioning of the jaws around the fitting
- ◆ fixes the sleeve to the fitting

## Press Fitting Installation

<p>1. Cut the pipe at a 90° angle</p>	<p>2. Bevel the cut end of the pipe</p>	<p>3. Check to ensure there are no burrs</p>
<p>4. Insert the pipe into the fitting and check that the pipe is visible in each of the 3 viewing windows</p>	<p>5. Using a standard 'U' profile press jaw and press tool, make the connection</p>	<p>6. Joint Complete</p>

# Size and Model of Press Fitting

## Equal Straight Union 16-32mm

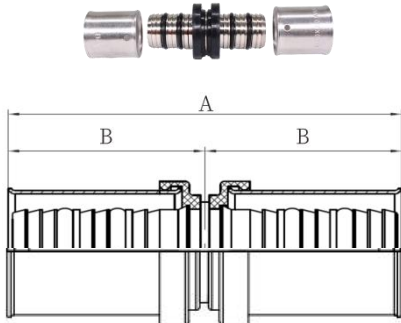

Type	Profile	A mm	B mm	Pcs/Pack	Code
16mmX16mm	U	53.2	26.6	10	ZL-KY101-S1616
20mmX20mm	U	53.2	26.6	7	ZL-KY101-S2020
25mmX25mm	U	68.4	34.2	4	ZL-KY101-S2525
32mmX32mm	U	69	34.5	2	ZL-KY101-S3232

## Unequal Straight Union 16-32mm

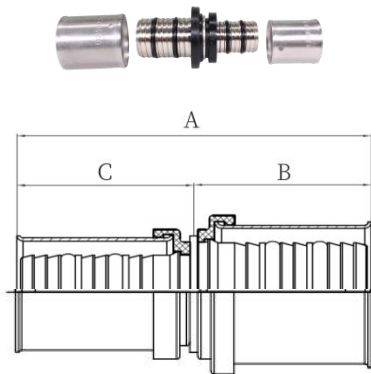

Type	Profile	A mm	B mm	C mm	Pcs/Pack	Code
20mmX16mm	U	53.2	26.6	26.6	5	ZL-KY102-S2016
25mmX16mm	U	60.8	34.2	26.6	5	ZL-KY102-S2516
25mmX20mm	U	60.8	34.2	26.6	4	ZL-KY102-S2520
32mmX16mm	U	61.1	34.5	26.6	5	ZL-KY102-S3216
32mmX20mm	U	61.1	34.5	26.6	5	ZL-KY102-S3220
32mmX25mm	U	68.7	34.5	34.2	5	ZL-KY102-S3225

## Male Straight Union 16-32mm

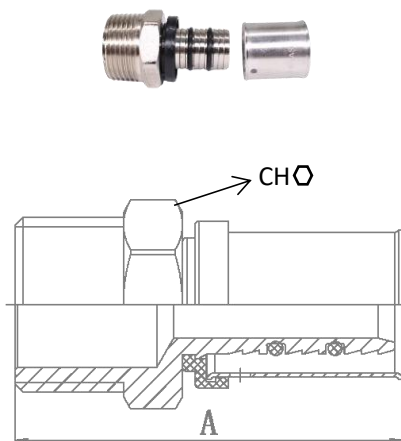

Type	Profile	A mm	CH mm	Pcs/Pack	Code
16mmX 1/2" M	U	46.1	22	10	ZL-KY103-S1612M
16mmX 3/4" M	U	47.1	27	5	ZL-KY103-S1634M
20mmX 1/2" M	U	46.4	22	5	ZL-KY103-S2012M
20mmX 3/4" M	U	47.1	27	5	ZL-KY103-S2034M
25mmX 1/2" M	U	53.7	22	5	ZL-KY103-S2512M
25mmX 3/4" M	U	54.7	27	5	ZL-KY103-S2534M
25mmX 1" M	U	58.2	34	5	ZL-KY103-S2511M
32mmX 3/4" M	U	55	29	4	ZL-KY103-S3234M
32mmX 1" M	U	58.5	34	4	ZL-KY103-S3211M
32mmX 1 1/4" M	U	63	42	1	ZL-KY103-S32114M

## Female Straight Union 16-32mm

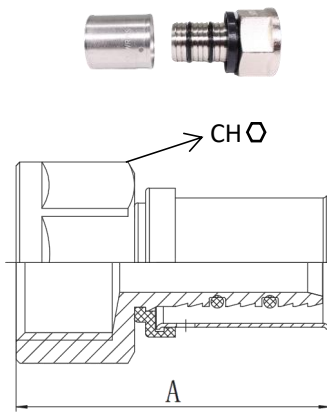

Type	Profile	A mm	CH mm	Pcs/Pack	Code
16mmX 1/2" F	U	42	24	5	ZL-KY104-S1612F
16mmX 3/4" F	U	44.3	30	5	ZL-KY104-S1634F
20mmX 1/2" F	U	42.3	24	5	ZL-KY104-S2012F
20mmX 3/4" F	U	44.3	30	5	ZL-KY104-S2034F
25mmX 3/4" F	U	51.7	30	5	ZL-KY104-S2534F
25mmX 1" F	U	52.6	36	4	ZL-KY104-S2511F
32mmX 3/4" F	U	51.9	30	4	ZL-KY104-S3234F
32mmX 1" F	U	52.9	36	4	ZL-KY104-S3211F
32mmX 1 1/4" F	U	55.9	46	1	ZL-KY104-S32114F

## Swivel Couple 16-25mm

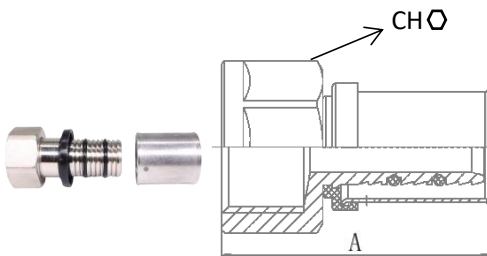

Type	Profile	A mm	CH mm	Pcs/Pack	Code
16mmX 1/2" F	U	44.9	24	10	ZL-KY105-1612F
20mmX 1/2" F	U	45.4	24	10	ZL-KY105-2012F
20mmX 3/4" F	U	45.4	30	5	ZL-KY105-2034F
25mmX 3/4" F	U	52.2	30	5	ZL-KY105-2534F

## Equal Elbow 16-32mm

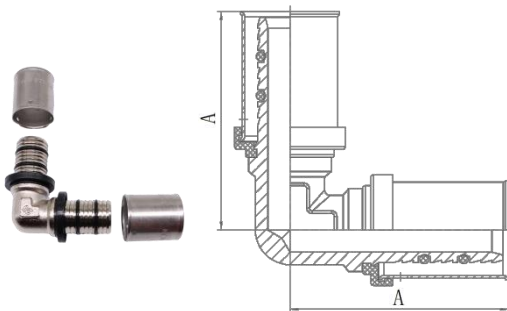

Type	Profile	A mm	Pcs/Pack	Code
16mmX16mm	U	39.1	6	ZL-KY106-L1616
20mmX20mm	U	40.6	6	ZL-KY106-L2020
25mmX25mm	U	50.2	3	ZL-KY106-L2525
32mmX32mm	U	53.6	2	ZL-KY106-L3232

## Swivel Elbow 16-20mm

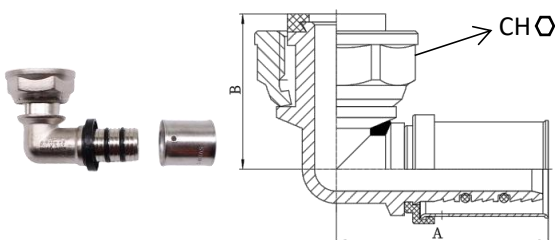

Type	Profile	A mm	B mm	CH mm	Pcs/Pack	Code
16mmX 1/2" F	U	38.9	28.5	26	6	ZL-KY109-1612F
20mmX 3/4" F	U	47.9	31.5	30	5	ZL-KY109-2034F

## Female Elbow 16-32mm

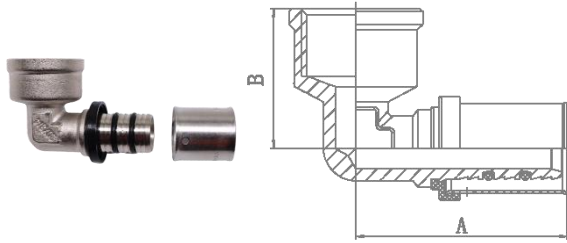

Type	Profile	A mm	B mm	Pcs/Pack	Code
16mmX ½" F	U	40.9	27	5	ZL-KY107-L1612F
16mmX ¾" F	U	44.9	28	5	ZL-KY107-L1634F
20mmX ½" F	U	40.9	30	6	ZL-KY107-L2012F
20mmX ¾" F	U	44.9	30	5	ZL-KY107-L2034F
25mmX ¾" F	U	52.2	32	4	ZL-KY107-L2534F
25mmX 1" F	U	56.7	35	4	ZL-KY107-L2511F
32mmX 1" F	U	56.5	38	2	ZL-KY107-L3211F

## Male Elbow 16-32mm

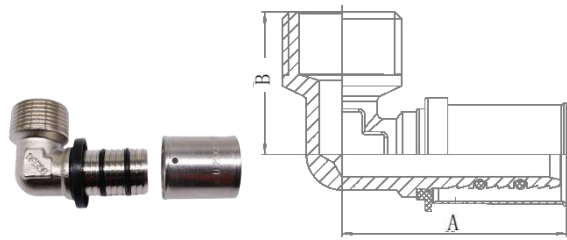

Type	Profile	A mm	B mm	Pcs/Pack	Code
16mmX ½" M	U	39.4	25	6	ZL-KY108-L1612M
20mmX ½" M	U	39.4	27	6	ZL-KY108-L2012M
20mmX ¾" M	U	41.9	29	5	ZL-KY108-L2034M
25mmX ¾" M	U	49.2	30.5	5	ZL-KY108-L2534M
32mmX 1" M	U	53	36	2	ZL-KY108-L3211M

## Unequal Tee 16-32mm

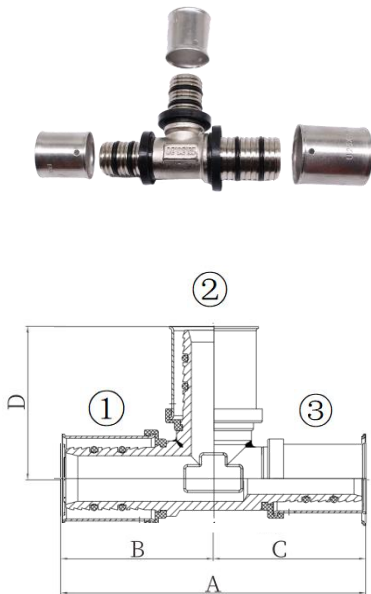

Type(①x②x③)	Profile	A mm	B mm	C mm	D mm	Pcs/Pack	Code
20mmX16mmX16mm	U	72.2	36.1	36.1	38.4	4	ZL-KY111-T201616
20mmX16mmX20mm	U	72.8	36.4	36.4	38.4	4	ZL-KY111-T201620
25mmX16mmX25mm	U	88.4	44.2	44.2	40.4	2	ZL-KY111-T251625
25mmX20mmX25mm	U	91.4	45.7	45.7	40.4	2	ZL-KY111-T252025
32mmX16mmX32mm	U	88	44	44	43.4	2	ZL-KY111-T321632
32mmX25mmX32mm	U	96	48	48	50.7	1	ZL-KY111-T322532
25mmX16mmX16mm	U	80.1	36.5	43.6	40.4	2	ZL-KY111-T251616
16mmX20mmX16mm	U	76.8	38.4	38.4	38.4	4	ZL-KY111-T162016
20mmX20mmX16mm	U	76.2	38.1	38.1	38.4	4	ZL-KY111-T202016
25mmX16mmX20mm	U	80.1	36.4	43.7	40.4	2	ZL-KY111-T251620
25mmX20mmX20mm	U	103.9	38.4	45.7	40.4	2	ZL-KY111-T252020
25mmX25mmX20mm	U	88.1	40.4	47.7	47.7	2	ZL-KY111-T252520
32mmX16mmX25mm	U	87.7	43.7	44	43.4	2	ZL-KY111-T321625
32mmX32mmX25mm	U	101.7	50.7	51	51	1	ZL-KY111-T323225
32mmX25mmX25mm	U	97.7	49.7	48	50.7	1	ZL-KY111-T322525
25mmX20mmX16mm	U	84.1	45.7	38.4	40.4	2	ZL-KY111-T252016
32mmX20mmX32mm	U	92	46.0	46	43.4	1	ZL-KY111-T322032
32mmX20mmX25mm	U	91.7	46.1	45.6	43.4	1	ZL-KY111-T322025
32mmX25mmX20mm	U	94.4	48	46.4	50.7	1	ZL-KY111-T322520

### Equal Tee 16-32mm

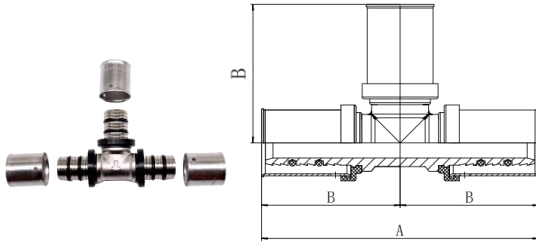

Type	Profile	A mm	B mm	Pcs/Pack	Code
16mmX16mmX16mm	U	72.2	36.1	5	ZL-KY110-T161616
20mmX20mmX20mm	U	76.2	38.1	3	ZL-KY110-T202020
25mmX25mmX25mm	U	95.4	47.7	2	ZL-KY110-T252525
32mmX32mmX32mm	U	102	51	1	ZL-KY110-T323232

### Female Tee 16-32mm

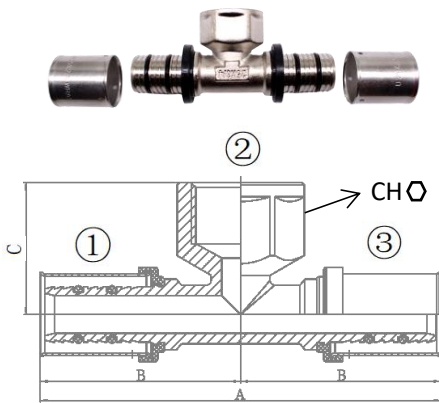

Type(①x②x③)	Profile	A mm	B mm	C mm	CH mm	Pcs/Pack	Code
16mmX½"FX16mm	U	84.8	42.4	28	24	4	ZL-KY112-T1612F16
16mmX¾"FX16mm	U	89.8	44.9	28	30	3	ZL-KY112-T1634F16
20mmX½"FX20mm	U	84.8	42.4	30	24	3	ZL-KY112-T2012F20
20mmX¾"FX20mm	U	90.8	45.4	31	30	3	ZL-KY112-T2034F20
25mmX½"FX25mm	U	99.4	49.7	30.2	24	2	ZL-KY112-T2512F25
25mmX¾"FX25mm	U	105.4	52.7	31.5	30	1	ZL-KY112-T2534F25
25mmX1"FX25mm	U	113.4	56.7	35	36	1	ZL-KY112-T2511F25
32mmX¾"FX32mm	U	104	52	32	30	1	ZL-KY112-T3234F32
32mmX1"FX32mm	U	111	55.5	39	36	1	ZL-KY112-T3211F32

### Hose Plate Female 16X15mm

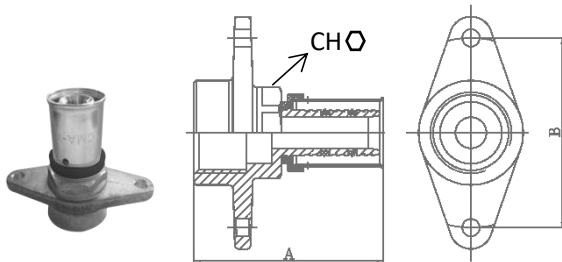

Type	Profile	A mm	B mm	CH mm	Pcs/Pack	Code
16mmX15mm	U	48.9	49	24	5	ZL-KY113-T1615

### Elbow with Plate-Male 16-20mm

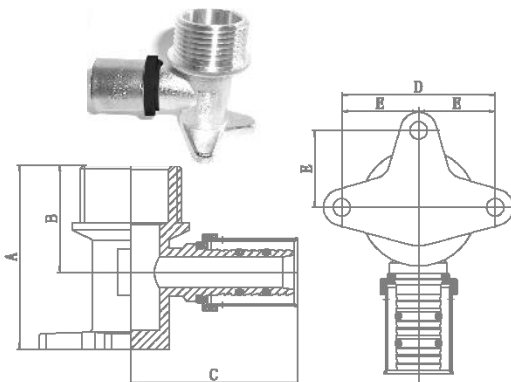

Type	Profile	A mm	B mm	C mm	D mm	E mm	Pcs/Pack	Code
16mmX ½"M	U	46	29.5	41.9	34	17	5	ZL-KY114-1612M
16mmX ¾"M	U	48	28	43.4	40	20	5	ZL-KY114-1634M
20mmX ¾"M	U	52	30	43.4	40	20	5	ZL-KY114-2034M

## Elbow with Plate-Female 16-20mm

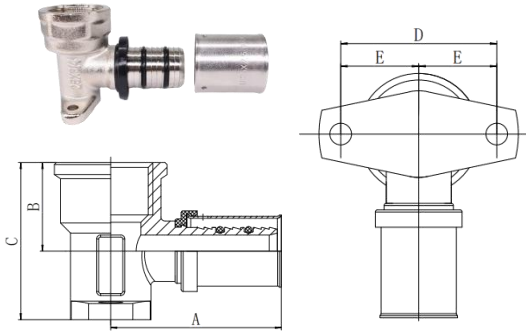

Type	Profile	A mm	B mm	C mm	D mm	E mm	Pcs/Pack	Code
16mmX 1/2"F	U	42	22	39	36	18	5	ZL-KY115-1612F
16mmX 3/4"F	U	45.4	29	46	36	18	5	ZL-KY115-1634F
20mmX 1/2"F	U	42.3	22	39	36	18	5	ZL-KY115-2012F
20mmX 3/4"F	U	45.4	29	46	40	20	5	ZL-KY115-2034F

## END CAP 16-32mm

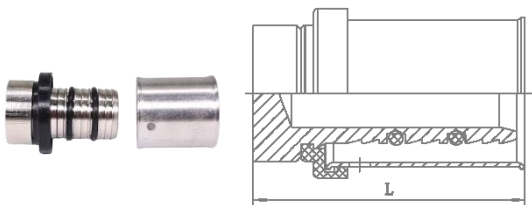

Type	Profile	L mm	Pcs/Pack	Code
16mm	U	31.6	10	ZL-KY116-16
20mm	U	34.1	10	ZL-KY116-20
25mm	U	41.7	5	ZL-KY116-25
32mm	U	43	5	ZL-KY116-32

## Copper Adapter 16-32mm

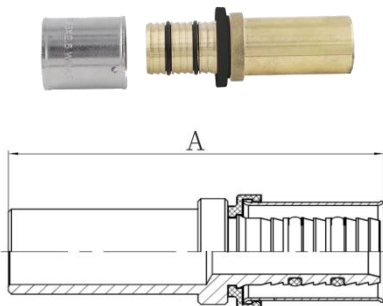

Type	Profile	A mm	Pcs/Pack	Code
16-15mm tail	U	62.6	9	ZL-KY117-1615
20-15mm tail	U	62.6	7	ZL-KY117-2015
20-22mm tail	U	71.1	6	ZL-KY117-2022
25-22mm tail	U	79.7	6	ZL-KY117-2522
32-28mm tail	U	84	2	ZL-KY117-3228

## Welded copper pipe elbow

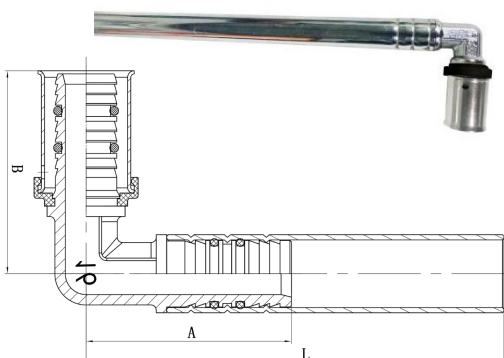

Type	Profile	A mm	B mm	L mm	Pcs/Pack	Code
L16*15 (300)	U	39.5	38.4	311.5	1	ZL-KY118-L1615300

## Installing the system

All installation operations must be carried out at temperatures above -10 °C and below 45 °C to avoid any possible damage to the materials.

In case of temperatures below 0 °C, store the materials (pipes and fittings) at a higher temperature before use.

### Removal of packaging from the pipe

1. Pay attention not to damage the pipe when removing the packaging tape from the roll.
2. For insulated pipe, make sure you do not cut into insulating sheath.

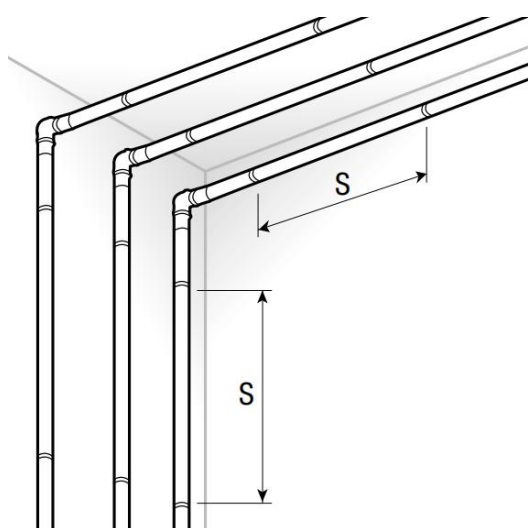
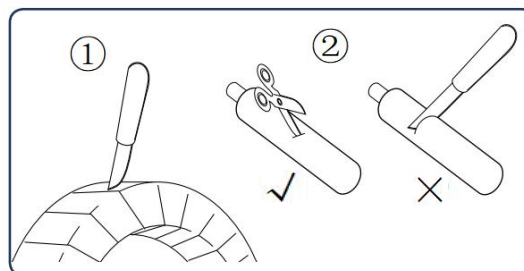

## Surface mounted installation

In surface mounted installations, in false ceilings, in the gaps of dry wall systems (e.g. plasterboard) and in shafts, the pipes must be adequately secured with suitable collars placed at a distance of no more than the value shown in the table below.

Maximum distance "S" for bracketing surface mounted pipes:

Pipe dimension	Maximum Distance (S) for bracketing (cm)
16 x 2	100
20 x 2	125
25 x 2.5	150
32 x 3	200

## Surface embedded installation

In surface embedded installations, the pipes must be suitably secured with ties and there must be a minimum distance between them of 80 cm on straight lengths, and placed 30 cm before and after each bend.

For this type of installation it is preferable to lay insulated pipe that has a foam sheath covering or pass the pipe through flexible tubing.

Press fittings: in laying concealed piping, the press fittings must be protected from corrosion that can result from contact with chemicals contained in plasters and mortars.

It is possible to use boxing, adhesive tapes specifically adapted for such applications, or coverings in an expanded plastic material that has been adequately sealed.

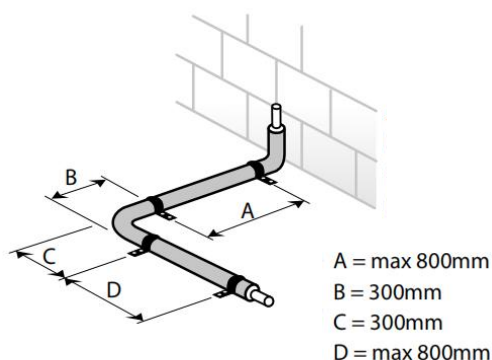

## Minimum radius of bends

The bending of pipes must be carried out in accordance with the minimum values provided by the following table.

Pipe dimension ( $\varnothing \times S$ )	Minimum radius of bend R	Minimum radius of bend R with spring pipe bender	Minimum radius of bend R with hydraulic bender
16 x 2	5 x $\varnothing$	3 x $\varnothing$	
20 x 2	5 x $\varnothing$	3 x $\varnothing$	
25x2.5	8 x $\varnothing$	4 x $\varnothing$	4 x $\varnothing$
32 x 3			4 x $\varnothing$

It is preferable to use elbow unions to form curves on pipes with a diameter greater than 26mm.

In bending the pipe you must also avoid putting pressure on the unions already installed and the distance between a union and the beginning of the bend must be greater than  $5x\varnothing$ , where  $\varnothing$  is the external diameter of the pipe.

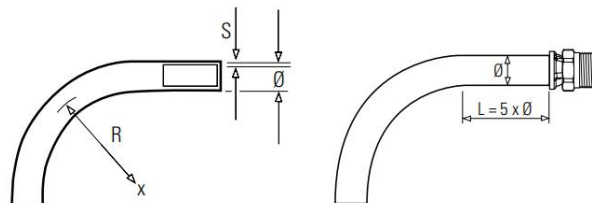

## Thermal expansion

During the installation phase, pay particular attention to thermal expansion that can particularly affect multilayer pipes. The elongation a pipe undergoes as a result of a variation in temperature can be calculated with the following formula:

$$\Delta L = \alpha \times L \times \Delta T$$

where:

$\alpha$  is the coefficient of linear expansion, equal to 0.026 mm/m K for insulated pipes;

L is the initial length of the pipe (m);

$\Delta T$  is the temperature difference (K).

Example:

Length of pipe: 10 m

Temperature difference: 50 K

$$\Delta L = 0.026 \times 10 \times 50 = 13.0 \text{ mm}$$

L = Length (m)

$\Delta T$  = Temperature difference (K)

$\Delta L$  = Longitudinal expansion (mm)

$\Delta T$	10	20	30	40	50	60	70
L	$\Delta L$						
0.1	0.026	0.052	0.078	0.104	0.130	0.156	0.182
0.2	0.052	0.104	0.156	0.208	0.260	0.312	0.364
0.3	0.078	0.156	0.234	0.312	0.390	0.468	0.546
0.4	0.104	0.208	0.312	0.416	0.520	0.624	0.728
0.5	0.130	0.260	0.390	0.520	0.650	0.780	0.910
0.6	0.156	0.312	0.468	0.624	0.780	0.936	1.092
0.7	0.182	0.364	0.546	0.728	1.910	1.092	1.274
0.8	0.208	0.416	0.624	0.832	1.040	1.248	1.456
0.9	0.234	0.468	0.702	0.936	1.170	1.404	1.638
1.0	0.260	0.520	0.780	1.040	1.300	1.560	1.820
2.0	0.520	1.040	1.560	2.080	2.600	3.120	3.640
3.0	0.780	1.560	2.340	3.120	3.900	4.680	5.460
4.0	1.040	2.080	3.120	4.160	5.200	6.240	7.280
5.0	1.300	2.600	3.900	5.200	6.500	7.800	9.100
6.0	1.560	3.120	4.680	6.240	7.800	9.360	10.920
7.0	1.820	3.640	5.460	7.280	9.100	10.920	12.740
8.0	2.080	4.160	6.240	8.830	10.400	12.480	14.560
9.0	2.340	4.680	7.020	9.360	11.700	14.040	16.380
10.0	2.600	5.200	7.800	10.400	13.000	15.600	18.200

## Pipe Support

In surface mounted installations or installations in false ceilings and shafts, longitudinal thermal expansion can be compensated for through careful arrangement of fixed and sliding brackets (points), depending on the type of installation, thus providing suitable thermal expansion compensators.

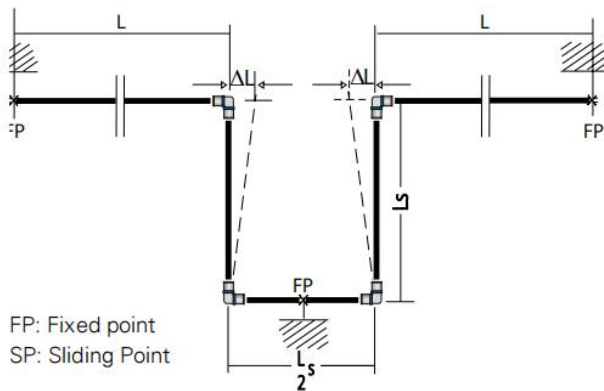

Where:

$$L_s = C \times \sqrt{\varnothing \times \Delta L}$$

$L_s$  = Length of compensator (mm)

$\varnothing$  = External diameter of pipe (mm)

$C$  = Material constant

(for insulated pipes  $C=33$ )

With

$\Delta L = 15,6$  mm (previous example),

$\varnothing = 26$  mm

the result will be:

$$L_s = 33 \times \sqrt{26 \times 15,6} = 665 \text{ mm}$$

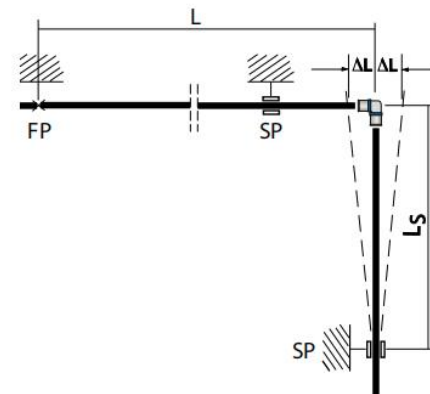
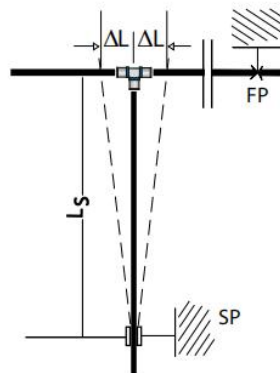

In order to guarantee the free movement of pipes in an installation inside a vertical shaft with horizontal branches, the branches must have a minimum free length  $L_s$  and the passage through the side wall of the shaft should be free and the pipe protected with a sheath (Fig. A and B).

In case the size of the shaft doesn't allow for a compensator of length  $L_s$ , the hole in the side wall should be increased in size and at the same time the tube should be protected with an insulating sheath of thickness  $S \geq 1,5 \times \Delta L$  (Fig. C).

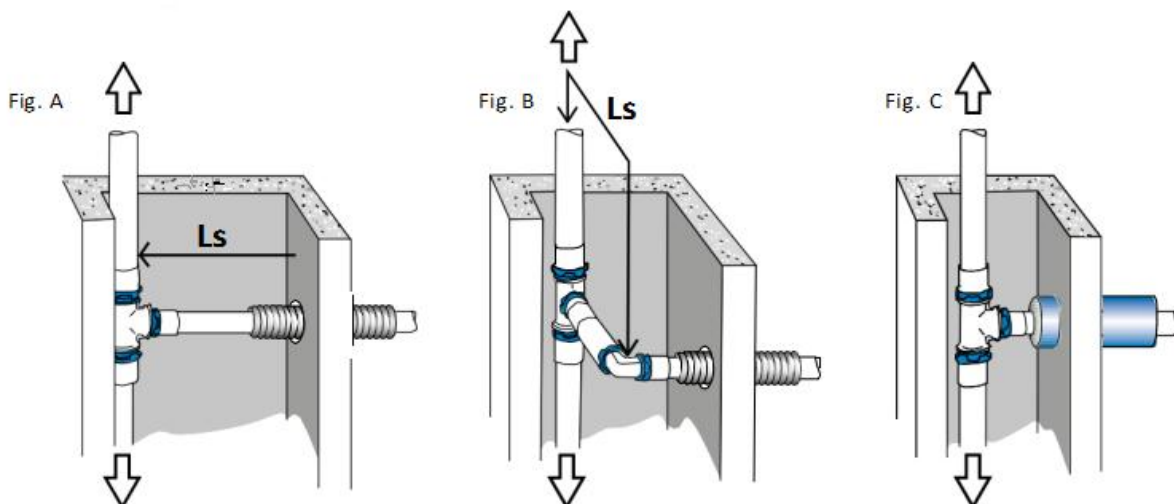

Where pipes are concealed or embedded in screed (laid in the floor), thermal expansion can be compensated for by creating an insulated curve at least every 10m (for example with an insulating foam sheath or by passing the pipe through flexible tubing).

Note: where the pipes are being used in radiant circuits (spiral or serpentine for underfloor heating/cooling), these guidelines do not apply!

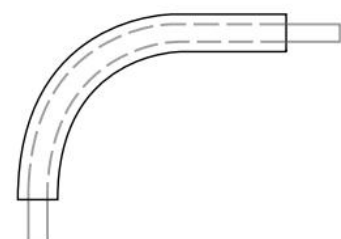

# Examples of installation

## Distribution with manifold

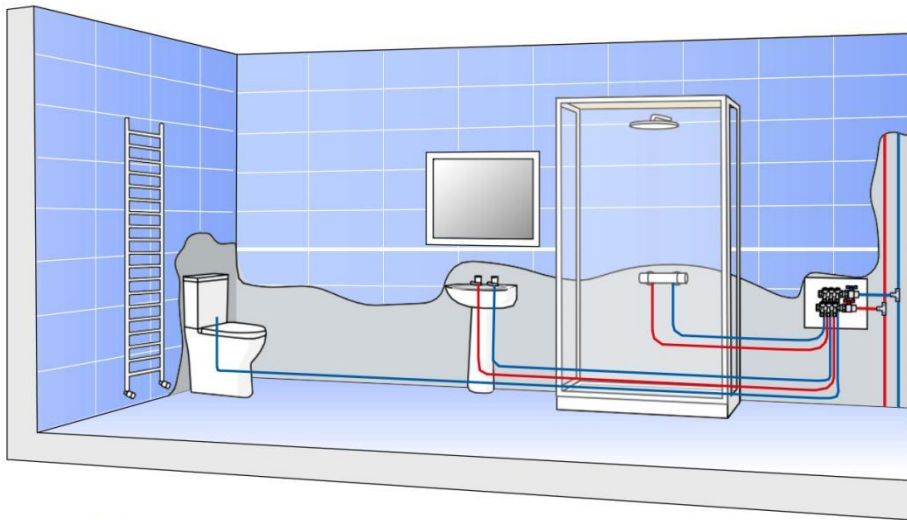

## Distribution with 'T' fitting

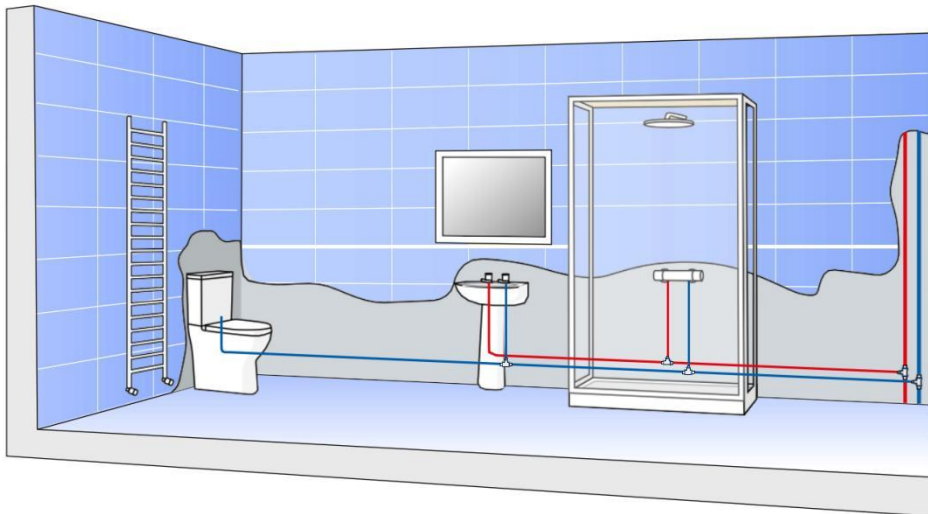

## Series distribution in a wall

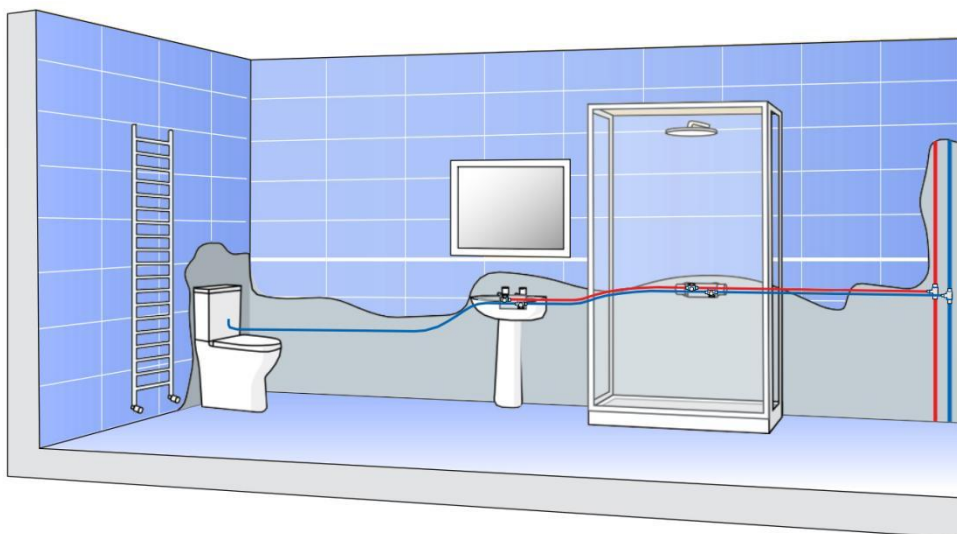

# Distributed Pressure Drops

Water at 10 ° C

DN 16x2			DN 20x2			DN 25x2.5			DN 32x3		
G (l/h)	V (m/s)	Dp/m (Pa/m)	G (l/h)	V (m/s)	Dp/m (Pa/m)	G (l/h)	V (m/s)	Dp/m (Pa/m)	G (l/h)	V (m/s)	Dp/m (Pa/m)
120	0.29	158	150	0.21	60	400	0.35	115	800	0.42	111
130	0.32	182	170	0.23	74	440	0.39	136	860	0.45	126
140	0.34	208	190	0.26	90	480	0.42	158	920	0.48	142
150	0.37	234	210	0.29	108	520	0.46	182	980	0.51	159
160	0.39	262	230	0.32	126	560	0.50	207	1040	0.54	176
170	0.42	291	250	0.35	146	600	0.53	234	1100	0.58	194
180	0.44	322	270	0.37	167	640	0.57	262	1160	0.61	213
190	0.47	354	290	0.40	189	680	0.60	291	1220	0.64	233
200	0.49	387	310	0.43	213	720	0.64	322	1280	0.67	253
210	0.52	422	330	0.46	237	760	0.67	354	1340	0.70	275
220	0.54	458	350	0.48	263	800	0.71	387	1400	0.73	296
230	0.56	495	370	0.51	290	840	0.74	422	1460	0.76	319
240	0.59	533	390	0.54	318	880	0.78	457	1520	0.80	342
250	0.61	572	410	0.57	347	920	0.81	494	1580	0.83	366
260	0.64	613	430	0.59	377	960	0.85	533	1640	0.86	391
270	0.66	655	450	0.62	408	1000	0.88	572	1700	0.89	416
280	0.69	698	470	0.65	441	1040	0.92	613	1760	0.92	443
290	0.71	742	490	0.68	474	1080	0.95	655	1820	0.95	469
300	0.74	788	510	0.70	508	1120	0.99	698	1880	0.98	497
310	0.76	834	530	0.73	544	1160	1.03	742	1940	1.01	525
320	0.79	882	550	0.76	580	1200	1.06	787	2000	1.05	553
330	0.81	930	570	0.79	617	1240	1.10	834	2060	1.08	583
340	0.84	980	590	0.82	656	1280	1.13	881	2120	1.11	613
350	0.86	1031	610	0.84	695	1320	1.17	930	2180	1.14	644
360	0.88	1084	630	0.87	736	1360	1.20	980	2240	1.17	675
370	0.91	1137	650	0.90	777	1400	1.24	1031	2300	1.20	707
380	0.93	1191	670	0.93	819	1440	1.27	1083	2360	1.23	739
390	0.96	1246	690	0.95	863	1480	1.31	1136	2420	1.27	773
400	0.98	1303	710	0.98	907	1520	1.34	1191	2480	1.30	806
410	1.01	1360	730	1.01	952	1560	1.38	1246	2540	1.33	841
420	1.03	1419	750	1.04	998	1600	1.41	1302	2600	1.36	876
430	1.06	1479	770	1.06	1045	1640	1.45	1360	2660	1.39	912
440	1.08	1539	790	1.09	1093	1680	1.49	1418	2720	1.42	948
450	1.11	1601	810	1.12	1142	1720	1.52	1478	2780	1.45	985
460	1.13	1664	830	1.15	1192	1760	1.56	1539	2840	1.49	1022
470	1.15	1728	850	1.17	1243	1800	1.59	1600	2900	1.52	1060
480	1.18	1793	870	1.20	1294	1840	1.63	1663	2960	1.55	1099
490	1.20	1858	890	1.23	1347	1880	1.66	1727	3020	1.58	1138
500	1.23	1925	910	1.26	1400	1920	1.70	1792	3080	1.61	1178
510	1.25	1993	930	1.28	1454	1960	1.73	1858	3140	1.64	1219
520	1.28	2062	950	1.31	1510	2000	1.77	1925	3200	1.67	1260
530	1.30	2132	970	1.34	1566	2040	1.80	1992	3260	1.71	1301
540	1.33	2203	990	1.37	1623	2080	1.84	2061	3320	1.74	1344
550	1.35	2275	1010	1.40	1680	2120	1.87	2131	3380	1.77	1386
560	1.38	2348	1030	1.42	1739	2160	1.91	2202	3440	1.80	1430
570	1.40	2422	1050	1.45	1799	2200	1.95	2274	3500	1.83	1474
580	1.42	2496	1070	1.48	1859	2240	1.98	2347	3560	1.86	1518
590	1.45	2572	1090	1.51	1920	2280	2.02	2421	3620	1.89	1563
600	1.47	2649	1110	1.53	1982	2320	2.05	2495	3680	1.93	1609
610	1.50	2727	1130	1.56	2045	2360	2.09	2571	3740	1.96	1655
620	1.52	2805	1150	1.59	2109	2400	2.12	2648	3800	1.99	1702

# Distributed Pressure Drops

Water at 50 ° C

DN 16x2			DN 20x2			DN 25x2.5			DN 32x3		
G (l/h)	V (m/s)	Dp/m (Pa/m)	G (l/h)	V (m/s)	Dp/m (Pa/m)	G (l/h)	V (m/s)	Dp/m (Pa/m)	G (l/h)	V (m/s)	Dp/m (Pa/m)
120	0.29	126	150	0.21	47	400	0.35	91	800	0.42	88
130	0.32	145	170	0.23	59	440	0.39	108	860	0.45	100
140	0.34	165	190	0.26	72	480	0.42	126	920	0.48	113
150	0.37	186	210	0.29	85	520	0.46	145	980	0.51	126
160	0.39	208	230	0.32	100	560	0.50	165	1040	0.54	140
170	0.42	231	250	0.35	116	600	0.53	186	1100	0.58	154
180	0.44	256	270	0.37	133	640	0.57	208	1160	0.61	169
190	0.47	281	290	0.40	150	680	0.60	231	1220	0.64	185
200	0.49	308	310	0.43	169	720	0.64	256	1280	0.67	201
210	0.52	335	330	0.46	188	760	0.67	281	1340	0.70	218
220	0.54	363	350	0.48	209	800	0.71	307	1400	0.73	235
230	0.56	393	370	0.51	230	840	0.74	335	1460	0.76	253
240	0.59	423	390	0.54	252	880	0.78	363	1520	0.80	272
250	0.61	454	410	0.57	275	920	0.81	393	1580	0.83	291
260	0.64	487	430	0.59	299	960	0.85	423	1640	0.86	311
270	0.66	520	450	0.62	324	1000	0.88	454	1700	0.89	331
280	0.69	554	470	0.65	350	1040	0.92	487	1760	0.92	351
290	0.71	589	490	0.68	376	1080	0.95	520	1820	0.95	373
300	0.74	625	510	0.70	404	1120	0.99	554	1880	0.98	394
310	0.76	662	530	0.73	432	1160	1.03	589	1940	1.01	417
320	0.79	700	550	0.76	461	1200	1.06	625	2000	1.05	439
330	0.81	739	570	0.79	490	1240	1.10	662	2060	1.08	463
340	0.84	778	590	0.82	521	1280	1.13	700	2120	1.11	487
350	0.86	819	610	0.84	552	1320	1.17	739	2180	1.14	511
360	0.88	860	630	0.87	584	1360	1.20	778	2240	1.17	536
370	0.91	903	650	0.90	617	1400	1.24	819	2300	1.20	561
380	0.93	946	670	0.93	651	1440	1.27	860	2360	1.23	587
390	0.96	990	690	0.95	685	1480	1.31	902	2420	1.27	613
400	0.98	1035	710	0.98	720	1520	1.34	945	2480	1.30	640
410	1.01	1080	730	1.01	756	1560	1.38	989	2540	1.33	668
420	1.03	1127	750	1.04	793	1600	1.41	1034	2600	1.36	696
430	1.06	1174	770	1.06	830	1640	1.45	1080	2660	1.39	724
440	1.08	1222	790	1.09	868	1680	1.49	1126	2720	1.42	753
450	1.11	1271	810	1.12	907	1720	1.52	1174	2780	1.45	782
460	1.13	1321	830	1.15	946	1760	1.56	1222	2840	1.49	812
470	1.15	1372	850	1.17	987	1800	1.59	1271	2900	1.52	842
480	1.18	1423	870	1.20	1028	1840	1.63	1321	2960	1.55	873
490	1.20	1476	890	1.23	1069	1880	1.66	1371	3020	1.58	904
500	1.23	1529	910	1.26	1112	1920	1.70	1423	3080	1.61	936
510	1.25	1583	930	1.28	1155	1960	1.73	1475	3140	1.64	968
520	1.28	1637	950	1.31	1199	2000	1.77	1528	3200	1.67	1000
530	1.30	1693	970	1.34	1243	2040	1.80	1582	3260	1.71	1033
540	1.33	1749	990	1.37	1288	2080	1.84	1637	3320	1.74	1067
550	1.35	1806	1010	1.40	1334	2120	1.87	1692	3380	1.77	1101
560	1.38	1864	1030	1.42	1381	2160	1.91	1748	3440	1.80	1135
570	1.40	1923	1050	1.45	1428	2200	1.95	1805	3500	1.83	1170
580	1.42	1982	1070	1.48	1476	2240	1.98	1863	3560	1.86	1205
590	1.45	2042	1090	1.51	1525	2280	2.02	1922	3620	1.89	1241
600	1.47	2103	1110	1.53	1574	2320	2.05	1981	3680	1.93	1277
610	1.50	2165	1130	1.56	1624	2360	2.09	2041	3740	1.96	1314
620	1.52	2227	1150	1.59	1675	2400	2.12	2102	3800	1.99	1351

# Distributed Pressure Drops

Water at 80 ° C

DN 16x2			DN 20x2			DN 25x2.5			DN 32x3		
G (l/h)	V (m/s)	Dp/m (Pa/m)	G (l/h)	V (m/s)	Dp/m (Pa/m)	G (l/h)	V (m/s)	Dp/m (Pa/m)	G (l/h)	V (m/s)	Dp/m (Pa/m)
120	0.29	117	150	0.21	44	400	0.35	85	800	0.42	82
130	0.32	135	170	0.23	55	440	0.39	101	860	0.45	94
140	0.34	154	190	0.26	67	480	0.42	117	920	0.48	105
150	0.37	173	210	0.29	80	520	0.46	135	980	0.51	118
160	0.39	194	230	0.32	93	560	0.50	154	1040	0.54	130
170	0.42	216	250	0.35	108	600	0.53	173	1100	0.58	144
180	0.44	238	270	0.37	124	640	0.57	194	1160	0.61	158
190	0.47	262	290	0.40	140	680	0.60	216	1220	0.64	172
200	0.49	287	310	0.43	157	720	0.64	238	1280	0.67	188
210	0.52	312	330	0.46	176	760	0.67	262	1340	0.70	203
220	0.54	339	350	0.48	195	800	0.71	287	1400	0.73	219
230	0.56	366	370	0.51	215	840	0.74	312	1460	0.76	236
240	0.59	394	390	0.54	235	880	0.78	339	1520	0.80	253
250	0.61	424	410	0.57	257	920	0.81	366	1580	0.83	271
260	0.64	454	430	0.59	279	960	0.85	394	1640	0.86	289
270	0.66	485	450	0.62	302	1000	0.88	423	1700	0.89	308
280	0.69	517	470	0.65	326	1040	0.92	454	1760	0.92	328
290	0.71	549	490	0.68	351	1080	0.95	485	1820	0.95	347
300	0.74	583	510	0.70	376	1120	0.99	516	1880	0.98	368
310	0.76	617	530	0.73	402	1160	1.03	549	1940	1.01	388
320	0.79	653	550	0.76	429	1200	1.06	583	2000	1.05	410
330	0.81	689	570	0.79	457	1240	1.10	617	2060	1.08	431
340	0.84	726	590	0.82	485	1280	1.13	652	2120	1.11	454
350	0.86	763	610	0.84	515	1320	1.17	688	2180	1.14	476
360	0.88	802	630	0.87	544	1360	1.20	725	2240	1.17	499
370	0.91	841	650	0.90	575	1400	1.24	763	2300	1.20	523
380	0.93	881	670	0.93	606	1440	1.27	802	2360	1.23	547
390	0.96	922	690	0.95	638	1480	1.31	841	2420	1.27	572
400	0.98	964	710	0.98	671	1520	1.34	881	2480	1.30	597
410	1.01	1007	730	1.01	705	1560	1.38	922	2540	1.33	622
420	1.03	1050	750	1.04	739	1600	1.41	964	2600	1.36	648
430	1.06	1094	770	1.06	774	1640	1.45	1006	2660	1.39	675
440	1.08	1139	790	1.09	809	1680	1.49	1050	2720	1.42	702
450	1.11	1185	810	1.12	845	1720	1.52	1094	2780	1.45	729
460	1.13	1231	830	1.15	882	1760	1.56	1139	2840	1.49	757
470	1.15	1279	850	1.17	920	1800	1.59	1185	2900	1.52	785
480	1.18	1327	870	1.20	958	1840	1.63	1231	2960	1.55	813
490	1.20	1375	890	1.23	997	1880	1.66	1278	3020	1.58	843
500	1.23	1425	910	1.26	1036	1920	1.70	1326	3080	1.61	872
510	1.25	1475	930	1.28	1076	1960	1.73	1375	3140	1.64	902
520	1.28	1526	950	1.31	1117	2000	1.77	1424	3200	1.67	932
530	1.30	1578	970	1.34	1159	2040	1.80	1475	3260	1.71	963
540	1.33	1630	990	1.37	1201	2080	1.84	1526	3320	1.74	994
550	1.35	1684	1010	1.40	1244	2120	1.87	1577	3380	1.77	1026
560	1.38	1737	1030	1.42	1287	2160	1.91	1630	3440	1.80	1058
570	1.40	1792	1050	1.45	1331	2200	1.95	1683	3500	1.83	1091
580	1.42	1848	1070	1.48	1376	2240	1.98	1737	3560	1.86	1124
590	1.45	1904	1090	1.51	1421	2280	2.02	1791	3620	1.89	1157
600	1.47	1960	1110	1.53	1467	2320	2.05	1847	3680	1.93	1191
610	1.50	2018	1130	1.56	1514	2360	2.09	1903	3740	1.96	1225
620	1.52	2076	1150	1.59	1561	2400	2.12	1960	3800	1.99	1260

# Press Fitting Pressure Drops

## Press Fitting Pressure Drop Calculation

To determine localised pressure drops of plants with fittings, it is possible to refer to the following values for the loss coefficient ( $\xi$ ), which can be obtained from technical literature.

$$\Delta p = \xi \rho v^2 / 2$$

$\Delta p$  = pressure drop (Pa = 0.01 mbar)

$\xi$  = loss coefficient

$\rho$  = volume mass of the fluid (kg/m<sup>3</sup>)

$v$  = speed of the fluid (m/s)

Water temperature [°C]	$\rho$ [kg/m <sup>3</sup> ]
20	0.9982
40	0.9922
60	0.99832
80	0.9718

Fitting figure	$\xi$
	1.8
	1.6
	4.1
	4.1
	4.1
	1.8
	7.6
	4.1